



COMET SYSTEM, s.r.o.

Bezrucova 2901
756 61 Roznov pod Radhostem
CZECH REPUBLIC
Tel.: +420 571 653 990

E-mail: info@cometsystem.com

T3113 Temperature and humidity duct probe with 4-20mA output



code: T3113

Humidity, temperature transmitter. Outdoor, indoor use. Duct mount.

Relative humidity, temperature sensors at 150mm stem. Measured values are also converted to other humidity interpretation: dew point temperature, absolute humidity, specific humidity, mixing ratio, specific enthalpy.

Included in delivery:

- Traceable calibration certificate
- Quick start manual
- Free program TSensor for configuring of the transmitter is ready to [Download](#)

Features

Programmable temperature and humidity transmitter is equipped with temperature and relative humidity sensors. Measured values are also converted to other humidity interpretation - dew point temperature, absolute humidity, specific humidity, mixing ratio or specific enthalpy. Degrees Celsius and Fahrenheit are user selectable. Transmitter contains a microprocessor

based control circuitry in a durable plastic case with connection terminals and sensors with filter with stainless steel mesh. Humidity transmitters is equipped with two galvanic isolated 4-20mA outputs. Configuration of outputs and output range are user adjustable. Large dual line LCD for simultaneous display of T+RH or other humidity interpretation is an advantage. Display is possible to switch off. Computerized design ensures temperature compensation of the humidity sensor and fail indication. State-of-the-art capacitive polymer sensor ensures excellent calibration long term stability, inertia against water and condensation. Transmitters are designed for use in non-aggressive environment.

APPLICATIONS - measuring and control of air humidity at:

- building HVAC management
- building HVAC automation
- warehouses
- glasshouses
- manufacturers
- museums, archives, galleries
- air-conditioned rooms
- weather stations

Outputs are set to maximum range from the manufacturer (-30 to +125°C, 0 to 100%RH).

To set other range by the user buying of SP003 cable is necessary - see Optional accessory.

Free configuration program TSensor for transmitter adjustment is ready to download anytime.

If different adjustment of outputs is required, please specify required output values (RH, T, Tdp, ..) and required ranges in the order. Adjustment is free of charge.

Any measured value - temperature, relative humidity, dew point temperature, absolute humidity, specific humidity, mixing ratio or specific enthalpy can be assigned to each output of the transmitter. Also identical value can be assigned to both outputs.

Ordering example: Transmitter T3113, output 1: RH 10 to 90%, output 2: temperature 0 to 35°C

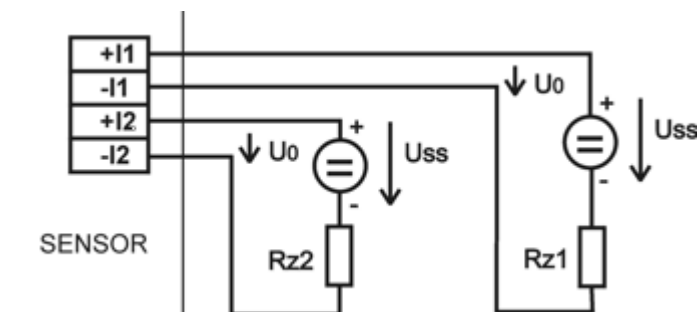

Typical application wiring of dual output transmitter

Calculation of minimum power voltage U_{ss} for proper operation:

$$U_{ss \text{ min}} > U_0 \text{ min} + I_{\text{max}} * R_z,$$

where: $U_0 \text{ min} = 9 \text{ V}$

I_{max} ... approximately 20 mA

R_z ... sensing resistor (shunt)

Both current loops (I1 and I2) are connected analogically, current loop I1 must be always connected.

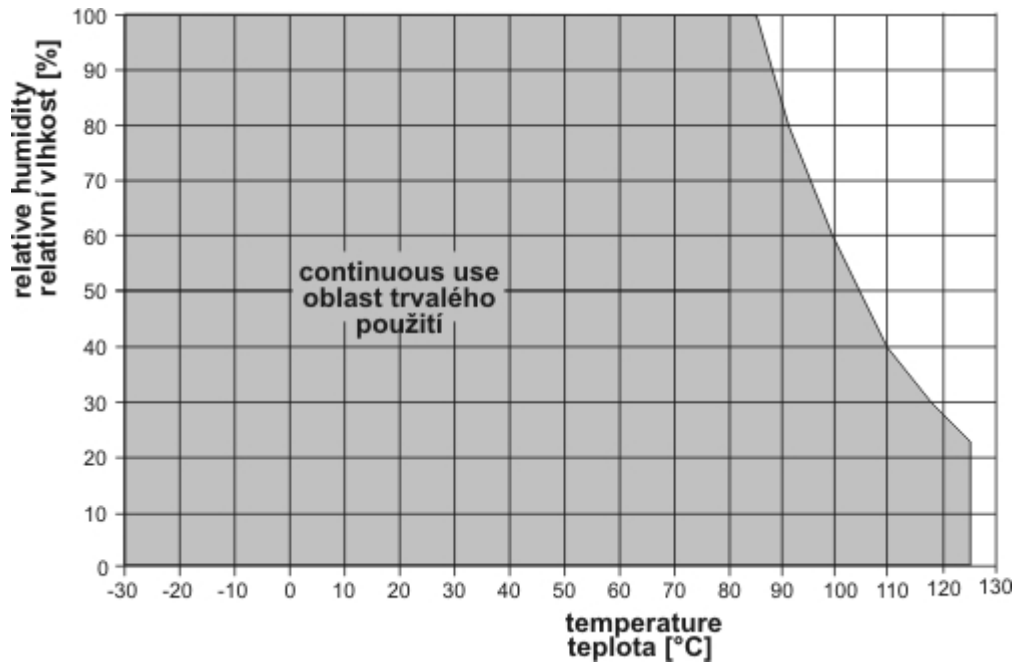

Figure: Relative humidity operating range

Technical Data

Technical parameters	Value
Output	4-20mA
Measured Value	Temperature + Relative Humidity
Construction Type	Duct Mount (150mm)
Design	Industrial
Temperature range	-30 to 125°C
Relative humidity range	0 to 100%
Accuracy of relative humidity measurement	±2.5% relative humidity from 5 to 95% at 23°C
Accuracy of temperature output	±0.4°C from -30 to +100°C ±0.4% from reading over +100°C
Available temperature units	degrees Celsius, Fahrenheit
Accuracy and range of dew point temperature output - for more details see graphs	±1.5°C at ambient temperature T < 25°C and RH > 30% range -60 to +80 °C
Accuracy and range of absolute humidity output	±1.5g/m ³ at ambient temperature T < 25°C range 0 to 400 g/m ³
Accuracy and range of specific humidity output	±2g/kg at ambient temperature T < 35°C range 0 to 550 g/kg
Accuracy and range of mixing ratio output	±2g/kg at ambient temperature T < 35°C range 0 to 995 g/kg
Accuracy and range of specific enthalpy output	±3kJ/kg at ambient temperature T < 25°C range: 0 to 995 kJ/kg
Temperature operating range of case with electronics	-30 to +80°C
Temperature operating range of LCD display	readable to operating temperature +70°C, it is recommended to switch OFF the LCD over +70°C

Range of humidity sensor temperature compensation	all temperature range
Current outputs - two-wire connection	4-20mA, galvanic isolated with dual-output models
Configuration of outputs and output range	user adjustable from the PC
Filtering ability of sensor cover	0.025mm - filter with stainless steel mesh
Protection of the case with electronics	IP65 electronics, IP40 sensors
Power	9-30Vdc
Dimensions	display unit 88.5 x 250 x 39.5 mm (W x H x D), stem length 150 mm
Weight	approximately 225g
Warranty	3 years